

Table of Contents:

Installer Responsibilities.....	Pg 2
Certification Details.....	Pg 2
System Components.....	Pg 3
System Layout Planning.....	Pg 6
Sub-structure assembly.....	Pg 6
Rail Installation.....	Pg 7
Solar Module Installation.....	Pg 8
Bonding Connections Ground Paths.....	Pg 9
System Grounding.....	Pg 11
Module Compatibility.....	Pg 13
Warranty.....	Pg 17

This installation manual is for use by professional installers who are trained and competent in all the required skills needed to complete system construction. This manual must be used in conjunction with project specific drawings which are provided for each installation by Solar Foundations USA[®], Inc. The project drawings are unique to each job site and are based on client specified configurations and local design conditions.

Installer Responsibilities:

- Comply with all national, state and local building codes, including any requirement that may supersede this installation manual. In the event of a conflict between this manual and any code, the installer shall contact Solar Foundations USA[®], Inc. prior to proceeding.
- Ensure the safe installation of all components and compliance with all OSHA rules and regulations.
- Ensure that the as built project meets the initial design basis including but not limited to verifying the mounting hardware is the correct size for the solar panel being installed.
- Use only Solar Foundations USA[®] supplied/specified parts. Substitution of parts may void the limited warranty.
- Solar Foundations USA recommends a periodic re-inspection of the completed installation for loose components, loose fasteners and any corrosion, such that if found, the affected components are to be immediately replaced.
- System routine maintenance shall not involve breaking or disturbing the bonding path of the system.

System Certification

The Solar Foundations Ground Mount Structure (Rack Mounting System) conforms to UL 2703 Standard for Safety First Edition: Mounting Systems, Mounting Devices, and Ground Lugs for Use with Flat-Plate Photovoltaic Modules and Panels for grounding and bonding.



Solar Foundations USA[®]
SFUSA GroundMount
Protected by U.S. Patents
Manufactured in New Castle, DE
Date of Mfg: _____

Component Identification

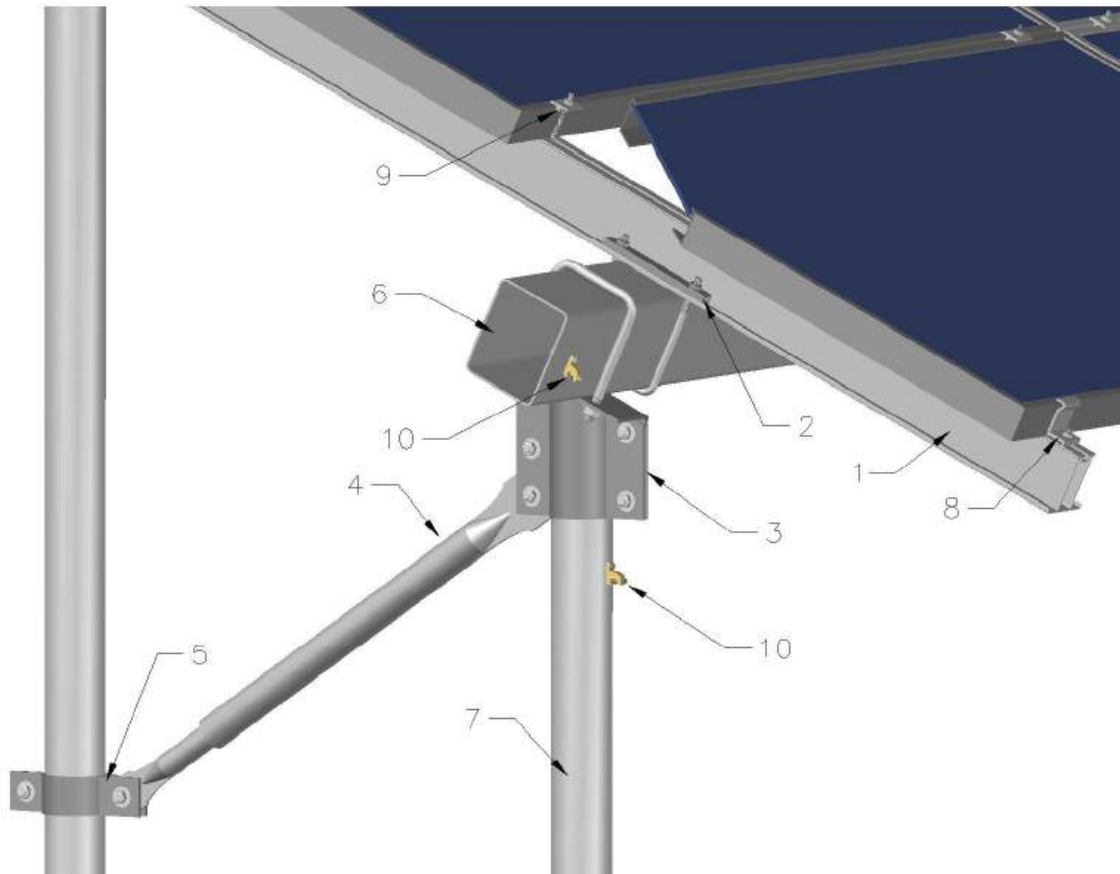

1 - SF Rail: Standard rail lengths are available for 4, 5 & 6 rows of panels in a landscape configuration. Custom lengths are available for a maximum of 8 rows of panels in a landscape configuration or a maximum of 5 rows of panels in a portrait configuration. Rail lengths allow a maximum short side panel dimension of 48" and a maximum long side panel dimension of 96".

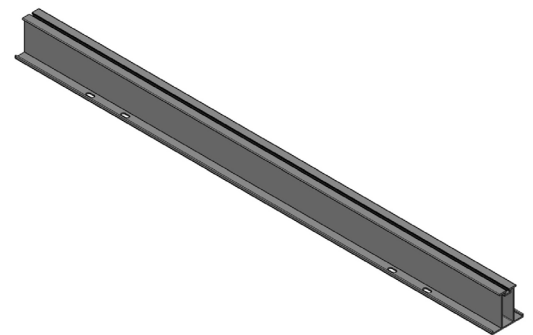

2- Rail Mounting Hardware: Fastens SF Rail to a square or rectangular horizontal beam. Includes 3/8" square bend U-bolt sized for specified beam, saddle and 3/8" nuts. All parts are hot dipped galvanized.

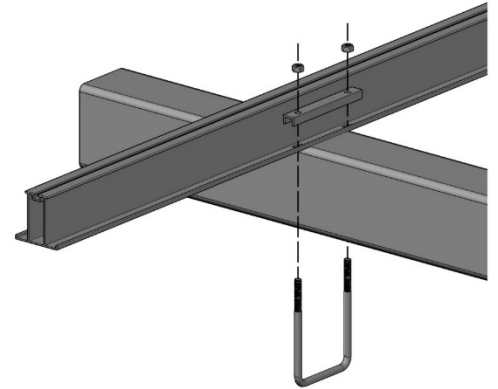

3 - Column Cap: Fastens a horizontal square or rectangular beam to the support column. Includes 1/2" square bend U-bolt sized for specified beam and 3/8" column cap assembly hardware. When required, the Diagonal Wind Brace connects directly to the South column cap. All parts are hot dipped galvanized.

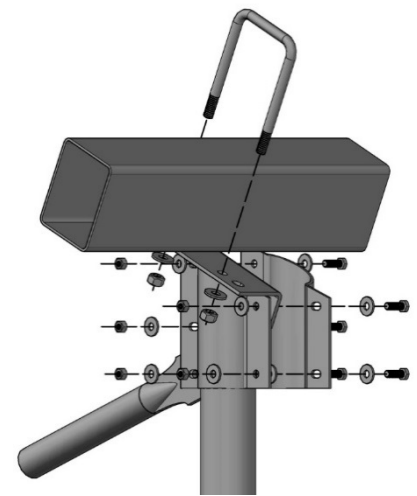

4 - Diagonal Wind Brace: Provides increased resistance to wind loads. Primary telescopic section is constructed from 1 1/4" Schedule 40 galvanized pipe. Includes 3/8" assembly hardware.

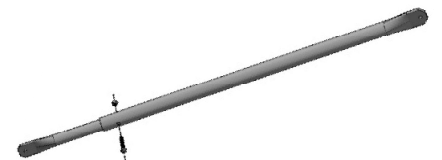

5 - Wind Brace Column Connector: Fastens the Diagonal Wind Brace to a vertical column. Includes 2 Column Connector halves and 3/8" assembly hardware. All parts are hot dipped galvanized.

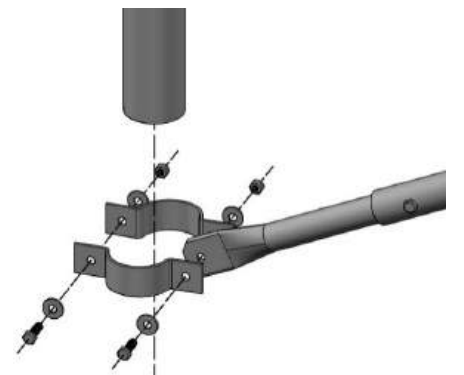

6- Horizontal Beam: Provides structural support for the SF Rails. Selection is based on project requirements and will be identified in the project specific plans. All parts are hot dipped galvanized.

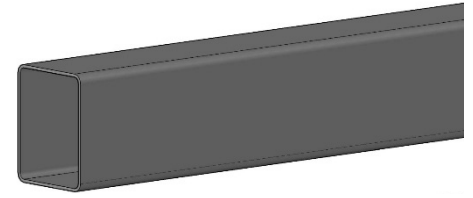

7 - Support Column: Depending on required height, the support column may be part of the installed continuous flight helical solar pile or may be an extension added onto the continuous flight helical solar pile. Support Column Extensions are made from 2-1/2" Schedule 40 pipe. All parts are hot dipped galvanized.



8 - Solar Module End Clamp: Fastens the last solar panel in a row of panels to the SF Rail. End Clamps are fastened with 18-8 Stainless $\frac{1}{4}$ -20 x $\frac{3}{4}$ " bolts and K-Lock nuts. Clamps are mill finish aluminum.

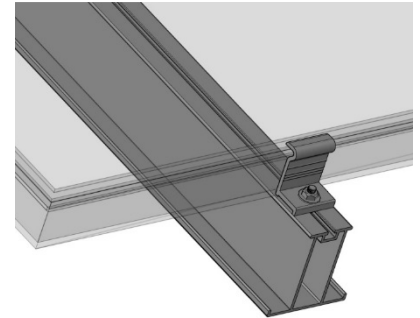

9 - Solar Module Mid Clamp: Fastens two adjoining solar panels in a row to the SF Rail. Mid Clamps are fastened with 18-8 Stainless $\frac{1}{4}$ -20 T-Head bolts and K-Lock nuts. Clamps are mill finish aluminum.

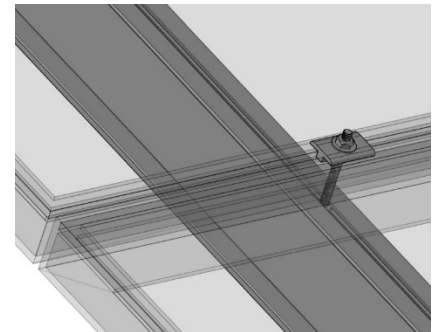

10 - Ground Lug: Installed at any one of the approved locations to provide complete Solar Foundations Ground Mount System grounding. Approved grounding lugs are detailed in the installation instructions.

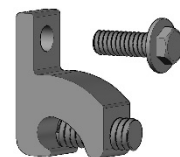

1. Column Location Layout

- 1.1 Prior to any excavation or penetration ensure all underground services have been clearly identified and that the required underground utility locating service notifications such as "Miss Utility" or "Dig-Safe" have been made.
- 1.2 Column locations shall be marked out in accordance with the project specific drawings provided for the installation.
- 1.3 Ensure the column layout is square by using a right angle laser, 3-4-5 right triangle rule or $a^2=b^2+c^2$.

2. Column Installation

- 2.1 The column type will be indicated on the project specific drawings. Most installations use helical piles for the columns but based on site conditions, concrete piers may be required.
- 2.2 All columns shall at a minimum, be installed to below the local frost depth.
- 2.3 When installing helical piles, ensure that the required load capacities as provided on the project specific drawings are obtained.
- 2.4 If the required pile capacities are not obtained or it becomes necessary to change a pile location due to an underground interference, contact the design engineer for resolution prior to continuing.
- 2.5 The South Columns are typically installed as a single length pile. Following installation cut the pile to the required South Column height as listed in the project specific plans.
- 2.6 The North Columns are typically installed as a two piece unit. The pile shall be installed to the required minimum depth and an above grade extension shall be installed to the required North Column height as specified in the project specific plans. The above grade extension can be field welded to the pile or connected with a threaded coupling. If a threaded coupling is used, the coupling must be above the Wind Brace Column Connector location.
- 2.7 Ensure all columns are installed plumb and within the required position tolerance. Straighten the South and North Columns as needed to ensure alignment.

3. Column Cap Assembly

- 3.1 Install Column Caps on the North and South columns. Column Cap component assembly should be in accordance with the exploded Column Cap view shown in the Component Identification section of this manual.
- 3.2 Tighten all bolts hand tight to permit minor alignment adjustments to be made.
- 3.3 When installing the Column Caps for HSS:
 - 3.3.1 Verify the rail span distance matches the span distance from the South to North Column Caps.
 - 3.3.2 Using an SF Rail as a straight edge, adjust the North and South Column Cap Mounting Plates so that they are tilted in the same plane.
 - 3.3.3 Tighten Column Cap Mounting Plate 3/8" Hardware to 25 ft-lbs.

4. Horizontal Beam Installation

- 4.1 Place the Horizontal Beams on the Column Caps and secure in place with the $\frac{1}{2}$ " U-Bolt provided by hand tightening the nuts.
- 4.2 When using rectangular or square HSS and the total required horizontal beam length exceeds the stock length available, it will be necessary to weld stock lengths together. Any required welding should be performed by a qualified welder and shall meet the weld requirements specified in the project specific drawings.
- 4.3 After all Horizontal Beams have been installed and verified to be in the correct position and alignment, tighten all $\frac{1}{2}$ " U-bolt Hardware to 40 ft-lbs.

5. SF Rail Installation

- 5.1 Mark centerline of the South Horizontal Beam by measuring $\frac{1}{2}$ the beam length and placing a mark.
- 5.2 Based on the South Horizontal Beam centerline mark, square back from the center of the South Horizontal Beam to the North Horizontal Beam and mark the corresponding centerline. Do not locate the North Horizontal Beam centerline by marking $\frac{1}{2}$ the North Beam length. You must square back from the South Horizontal Beam to ensure the racking installation is maintained square.
- 5.3 Measure and mark the West SF Rail starting position on both North and South horizontal beams. The West SF Rail starting position and subsequent rail spacing are determined from the centerline offset and SF Rail spacing which are provided with the project specific drawings.
- 5.4 Based on the West SF Rail starting position, layout the remainder of SF Rail positions on the North and South Beams. For short East-West array lengths, fixed spacers may be used to space the SF Rails.
- 5.5 Install the SF Rails and fasten in accordance with the exploded rail mounting bracket view shown in the Component Identification section of this manual. When possible, place the North and South rail $\frac{3}{8}$ " u-bolt on opposite sides of the SF Rail. When required by the project specific drawings, fasten the SF Rail with (2) $\frac{3}{8}$ " SF Rail u-bolts on both North and South Horizontal Beams.
- 5.6 Torque all $\frac{3}{8}$ " SF Rail mounting bracket to 120 in-lbs.

6. Diagonal Wind Brace Installation

- 6.1 Fasten the 1-1/4" end of Telescopic Diagonal Wind Bracing to the South Column Cap lower bolt in accordance with the exploded column cap view shown in Section 1 of this manual.
- 6.2 Insert the 1" extension into the 1-1/4" section and fasten the 1" end of Telescopic Diagonal Wind Bracing to the North Column in accordance with the exploded Wind Brace Column Connector view shown in the Component Identification section of this manual. The Column Connector shall be no more than 6" above grade at the North column.
- 6.3 Verify that there is no more than 18" of 1" pipe extending from the 1-1/4" section.
- 6.4 Drill a 7/16" hole through the Diagonal Wind Brace a minimum of 2" from the end the 1-1/4" section of Diagonal Wind Brace. Install a $\frac{3}{8}$ " bolt and tighten the nut to 25 ft-lbs.

7. Final Structure Assembly

- 7.1 Tighten all 3/8" Galvanized Column Cap hardware and Wind Brace Column Connector hardware. Both Column Cap and Column Connector halves must be in contact with each other following tightening. If necessary, an additional spacing washer may be added between Cap or Connector halves as long as bolt torques exceeds 180 in-lbs before full contact is achieved. Torque all fasteners to 25 ft-lbs.
- 7.2 If required by the project specific drawings, install (1) 1/4"-20 Elco Drill Flex[®] self tapping screw (or equal) through one of the 5/16" holes provided in the Column Cap. Two holes are provided to allow for installation flexibility.

8. Solar Panel Mounting

- 8.1 Stainless steel hardware can seize up in a process known as galling. To significantly reduce the probability of galling, the use a stainless steel anti-seize lubricant is recommended.
- 8.2 Determine the solar panel bottom of rail offset by subtracting the combined width of the solar panels plus panel spacing from the length of the SF Rail and dividing by 2.
 - 8.2.1 [SF Rail Length - (# of Rows x Panel width) - ((# of Rows -1) x Panel spacing)]/2
 - 8.2.2 Typical solar panel bottom of rail offsets are approximately 2"
- 8.3 Establish a straight line across the bottom of all SF Rails at the bottom of rail offset position. This can be done with a string line or laser for longer distances.
- 8.4 Install the module End Clamps backwards using 1/4"-20x3/4" 18-8 stainless hex head bolts and k-lock nuts provided such that the bottom lip of the End Clamp is positioned on the bottom of rail offset line. These clamps will be used as a positioning guide for the first row of solar panels.
- 8.5 Place the first row of solar panels in place allowing for the solar panels to rest against the bottom lip of the End Clamps previously installed. Ensure a minimum east-west panel gap of 1/4" is maintained or larger as required by design or panel manufacturer.
- 8.6 After the first row of solar panels is installed and correctly spaced, install the second row of solar panels and fasten the solar panels with Mid Clamps using 1/4"-20 18-8 stainless steel quarter turn T-head bolts and k-lock nuts provided in accordance with the exploded Mid Clamp view shown in the Component Identification section of this manual. Please refer to the Grounding and Bonding section of this manual for placement of SF Integrated Bonding Mid Clamps or alternate use of the WEEB-DMC.
- 8.7 Tighten the Mid Clamp nut to 120 in-lbs.

 Failure to turn the T-head bolt one quarter turn and verify the head of the bolt has engaged the bolt channel in the rail before tightening will cause improper hold down of the solar panel and may result in solar panels being blown off the racking in wind conditions.

 Proper engagement of the T-head bolt can be verified by confirming the indicating line on the end of the T-head bolt is perpendicular to the SF Rail.

- 8.8 Following installation of the first row of Mid Clamps, one at a time, loosen and rotate the End Clamps installed in step 9.4 into their correct orientation. Tighten the End Clamp nut to 120 in-lbs.
- 8.9 Complete installation of the remaining solar panels as described in the above steps.

9. Bonding Connection Ground Paths

The SF Rail System utilizes top mounting clamps which have been evaluated for frame-to-system bonding at specified mounting hardware torque values. The SF Rail System may be used to ground and/or mount a PV module complying with UL 1703 only when the specific module has been evaluated for grounding and/or mounting in compliance with the instructions. The grounding method is to be used in accordance with the National Electric Code, ANSI/NFPA 70. Either of the following two options may be used to bond the solar modules to the racking system.

The maximum Overcurrent Protective Device (OCPD) Rating for this system is 30A.

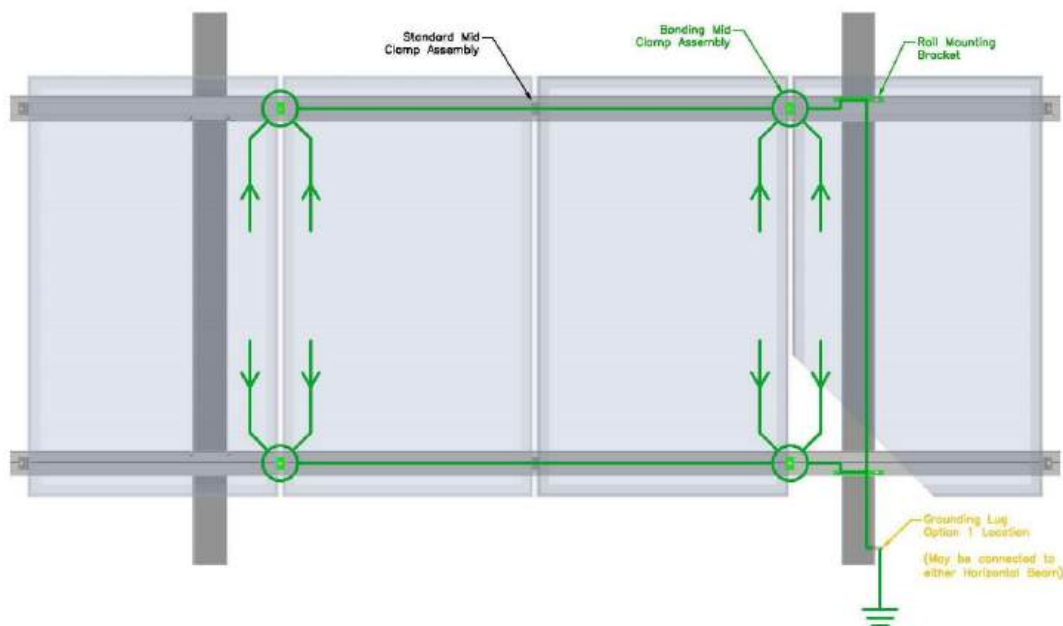

9.1 Option 1 - CSET Bonding Mid Clamp - Ground Connection Path

9.1.1 Component Identification

Part #1: 1/4-20 K-Lock Nut, 300 Series Stainless Steel

Part #2: Integrated Bonding Mid Clamp (IB-MC), 6000 Series Aluminum

Part #3: Counter Sunk External Tooth Lockwasher (CSET), 300 Series Stainless Steel

Part #4: 1/4-20 T-Head Bolt with Alignment Indicator, 300 Series Stainless Steel

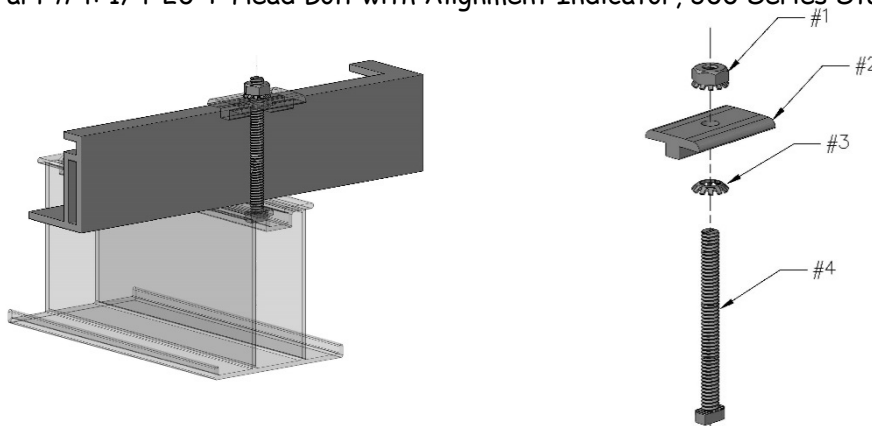

9.1.2 Assembly

- 9.1.2.1** Insert the T-Head bolt into the rail and turn 90 degrees clockwise. Proper engagement can be confirmed by observing the alignment indicator located on the end of the bolt is perpendicular to the rail length.
- 9.1.2.2** Insert the CSET Lockwasher into the recessed cavity located on the underside of the Integrated Bonding Mid Clamp. Ensure the teeth of the CSET are facing toward the solar module as shown in the above part stack up drawing.
- 9.1.2.3** With the T-Head bolt pinned between two adjacent solar modules, place the Integrated Bonding Mid Clamp on the T-Head bolt with CSET Lockwasher as shown in the above sketch (one adjacent solar module omitted for clarity).
- 9.1.2.4** Ensure the T-Head Bolt alignment indicator is in the correct orientation and then install the K-Lock nut and torque to 120 in-lbs. While not required, the use of an anti-seize compound is recommended to minimize the potential for galling of stainless fasteners.
- 9.1.2.5** The CSET Lockwasher and IB-MC are Single Use Only items and cannot be reused following initial installation.

9.1.3 Locations

- 9.1.3.1** An IB-MC with CSET Lockwasher shall be placed at the mid clamp location between each pair of adjacent solar modules such that each solar module is bonded to each rail at a minimum of one location per rail.
- 9.1.3.2** When there is an even number of solar modules in the column of panels, the quantity of IB-MC's with CSET Lockwashers per rail will be equal to the quantity of solar modules divided by 2.
- 9.1.3.3** When there is an odd number of solar modules in the column of panels, the quantity of IB-MC's with CSET Lockwashers per rail will be equal to (the quantity of solar modules plus 1) divided by 2.

9.2 Option 2 - WEEB-DMC Bonding Mid Clamp - Ground Connection Path

9.2.1 Component Identification

Part #1: 1/4-20 K-Lock Nut, 300 Series Stainless Steel

Part #2: Standard Mid Clamp (MC), 6000 Series Aluminum

Part #3: 1/4-20 T-Head Bolt with Alignment Indicator, 300 Series Stainless Steel

Part #4: WEEB-DMC, For Use with Solar Foundations Racking and Compatible Modules

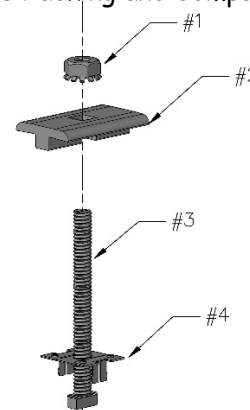
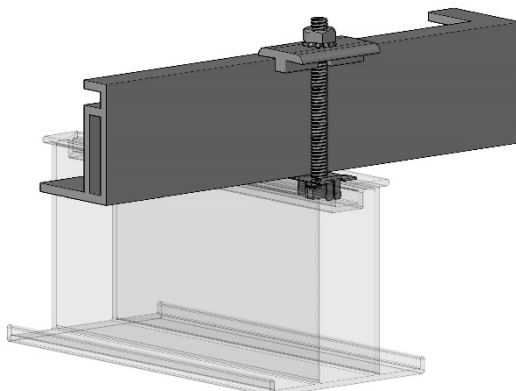

9.2.2 Assembly

- 9.2.2.1 Pre-assemble the WEEB-DMC to Mid Clamp assembly as shown in the above sketch.
- 9.2.2.2 Insert the pre-assembled WEEB-DMC and Mid Clamp assembly into the rail as shown above.
- 9.2.2.3 Slightly lift the solar module and slide the WEEB-DMC and mid clamp assembly into position. WEEB teeth will automatically be aligned under the edge of the module when the mid clamp assembly is correctly installed.
- 9.2.2.4 With the T-Head bolt pinned between two adjacent solar modules, ensure that the WEEB is correctly in place between the two adjacent solar modules as shown above. (one adjacent solar module omitted for clarity).
- 9.2.2.5 Ensure the T-Head Bolt alignment indicator is in the correct orientation and then torque the K-Lock nut to 120 in-lbs. The use of a general purpose anti-seize compound is required at all WEEB-DMC Bonding Mid Clamp locations.
- 9.2.2.6 The WEEB-DMC is a Single Use Only item and cannot be reused following initial installation.

9.2.3 Locations

- 9.2.3.1 A WEEB-DMC Bonding Mid Clamp shall be placed at the mid clamp location between each pair of adjacent solar modules such that each solar module is bonded to each rail at a minimum of one location per rail.
- 9.2.3.2 When there is an even number of solar modules in the column of panels, the quantity of WEEB-DMC Bonding Mid Clamp's per rail will be equal to the quantity of solar modules divided by 2.
- 9.2.3.3 When there is an odd number of solar modules in the column of panels, the quantity of WEEB-DMC Bonding Mid Clamp's per rail will be equal to (the quantity of solar modules plus 1) divided by 2.

10. System Ground Connections

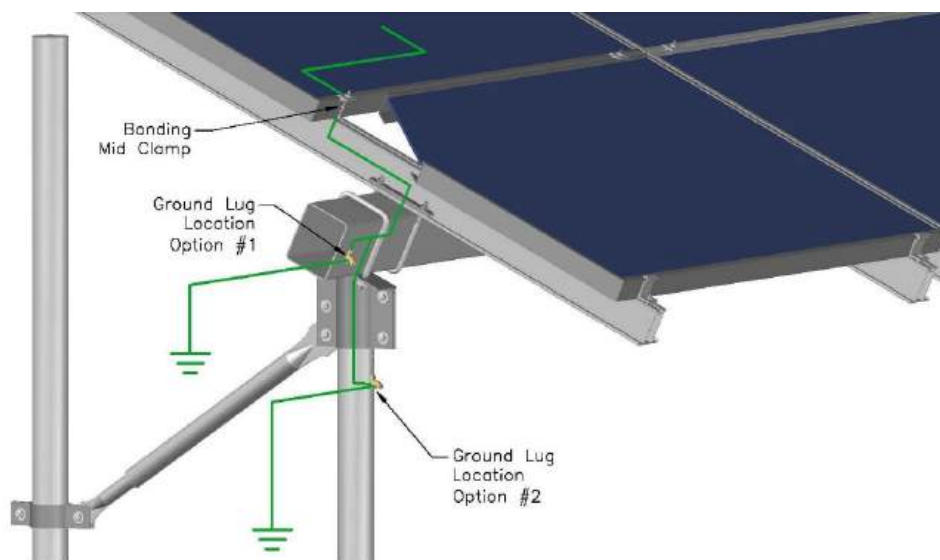

- 10.1** Two options are available for installation location of the system ground lug. Both ground path options require that the system structure be assembled in accordance with sections 2 thru 8 of this manual. All required torque specifications for individual components are included in the applicable section of this manual.
- 10.2** The following Lay-In ground lugs are certified for use with the Solar Foundations GroundMount System:
- 10.2.1** Brumall Mfg. Corp, Part# GLC-4DB (4-14 awg Solid Copper)
 - 10.2.2** IlSCO, Part# GBL-4SS-ILSC (4-14 awg Solid Copper)
 - 10.2.3** Morris, Part# 90573 (4-14 awg Solid Copper)
- 10.3** Ground Lug Location Option #1
- 10.3.1** A single Ground Lug may be installed at any location along the length of either the north or south Horizontal Beam. Any of the 4 faces of the beam are acceptable locations.
 - 10.3.2** Attach one of the approved ground lugs using an Elco EAF460 Dril-Flex[®] Fastener. The ground lug shall be placed on the fastener prior to drilling the fastener in place.
 - 10.3.3** With an electric drill, screw the fastener in until it is fully screwed in and begins to clamp the ground lug in place. Do not overtighten or fastener failure may occur. Once the fastener has been fully threaded in, back the fastener out 1 full turn.
 - 10.3.4** Complete the mounting by tightening the Elco EAF460 Dril-Flex[®] Fastener to 50 in-lbs.
 - 10.3.5** Install the solid copper ground wire and torque the retaining set screw to the following:
 - 4-6 AWG wire: 35 in-lbs.
 - 8 AWG wire: 25 in-lbs.
 - 10-14 AWG wire: 20 in-lbs.
 - 10.3.6** Installation must be in accordance with NFPA NEC 70, however the electrical designer of record should refer to the latest revision of NEC for actual grounding conductor cable size.
- 10.4** Ground Lug Location Option #2
- 10.4.1** A single Ground Lug may be installed at any location along any Support Column.
 - 10.4.2** Due to the wall thickness of the support columns, it will be necessary to predrill for the Elco EAF460 Dril-Flex[®] Fastener. At the desired mounting location, pre-drill a hole using a #20 Drill Bit.
 - 10.4.3** Attach one of the approved ground lugs using an Elco EAF460 Dril-Flex[®] Fastener. The ground lug shall be placed on the fastener prior to drilling the fastener in place.
 - 10.4.4** With an electric drill, screw the fastener in until it is fully screwed in and begins to clamp the ground lug in place. Do not overtighten or fastener failure may occur. Once the fastener has been fully threaded in, back the fastener out 1 full turn.
 - 10.4.5** Complete the mounting by tightening the Elco EAF460 Dril-Flex[®] Fastener to 50 in-lbs.
 - 10.4.6** Install the solid copper ground wire and torque the retaining set screw to the following:
 - 4-6 AWG wire: 35 in-lbs.
 - 8 AWG wire: 25 in-lbs.
 - 10-14 AWG wire: 20 in-lbs.
 - 10.4.7** Installation must be in accordance with NFPA NEC 70, however the electrical designer of record should refer to the latest revision of NEC for actual grounding conductor cable size.

11. Module Compatibility

Amerisolar: AS-(5M, 5M12, 5M18, 6M, 6M18, 6M24, 6M27, 6M30, 6P, 6P18, 6P27, 6P30)-xxx (Blank, Black, Transparent, PERC) with 35mm, 40mm Frames

Aleo: P23Lxxx, Silver with 35mm Frames

Aptos Solar: DNA-(120, 144)-(MF, BF)(23, 26)-xxx Black with 35mm, 40mm Frames

Auxin: AXN6(M,P)6(10, 12)Txxx Silver & Black with 40mm Frames

AXITEC Solar: AC-xxx(M, P)/156-(60,72)S with 35mm, 40mm Frames

Boviet Solar: BVM(6610P, 6612P, 6610M, 6612M)-xxx with 40mm Frames

BYD: (P6C, PHK, M6K, MHK)-(30,36) Silver with 35mm, 40mm Frames

Canadian Solar: CS(1H, 1Y, 1U, 3W, 3K, 3U, 6K, 6P, 6U, 6X)-xxx(M, MS, P, PB-AG, MB-AG) Silver & Black with 30mm, 35mm, 40mm Frames

CertainTeed: CTxxx(MXX,HC11)-(01, 02, 03, 04) Silver & Black with 35mm, 40mm Frames

ET Solar: ET-(M6, P6)(72)xxx(BB, WB, WW) with 40mm Frames

GCL: GCL-(M6, P6)/72(H, Blank) Silver with 35mm Frames

Hansol: HSxxx(UD,TD)-AN(1,3) Silver with 35mm, 40mm Frames

Hanwha Q CELLS: Q.(PRO, PLUS, PEAK)-(G3, BLK-G3, BFR-G3, G4, BFR-G4, G4.1, G4.1/SC, BFR-G4.1, BLK-G4.1, L-G4.2, BFR-G4.3, G5)-xxx with 32mm, 35mm, 40mm, 42mm Frames

Hanwha Solar: HSL (60, 72) (P6)-(PC, PB)-(1, 3, 4)-xxx with 32mm, 40mm Frames

Heliene: 72(M,P)(Blank, BLK G1) Silver & Black with 40mm Frames

HT-SAAE Solar: (HT60, HT72)-(156M, 166M)-(Blank, M) Silver with 35mm Frames

Hyundai Green Energy: HiS-(M, S)xxx(MG, RG, RI, TI) (Blank, BK) with 35mm, 40mm 50mm Frames

ITEK: SE 60-Cell Silver with 40mm Frames

JA Solar: JA(M6, P6)(Blank, K)(Blank, TG, SE)-(48, 60, 72)-xxx/(SI, 3BB, 4BB, PR)/(Blank, RE) with 35mm, 40 mm Frames

Japan Solar: JPS-xxx(M, P)-(60, 72) Silver & Black with 35mm, 40mm Frames

Jinko: JKM(Blank, S)xxx(M, P, PP)-(Blank, 6RL3, 60, 60V, 60L, 60B, 60BL, 60HL, 60H, 60HBL, 72, 72H, 72H-BDVP, 7RL3-V) Silver & Black with 30mm, 35mm, 40mm Frames

Kyocera: (KD, KU)xxx(Blank, GX, SX)-(6MCA, LFU, LFBS, UFU, UFBS) Black with 46mm Frames

LG Electronics: LGxxx(Q, N, S, E)(1 or 2)(C, W, K)-(G3, B3, L4, G4, A5) with 35mm, 40mm or 46mm Frames

LONGi Solar: LR(4,6)-(60,72)(BP, PB, PE, PH, HV, HPB, HPH, Blank)-xxxM Silver & Black with 30mm, 35mm, 40mm, 45mm Frames

Mission Solar: MSExxx(SQ5T, SO6J, SQ6S, SQ8K, SQ5K, SQ9S, SQ8T, SR9S, SR8T) Silver & Black with 40mm Frames

Mitsubishi Electric: PV-MLExxx(HD, HD2) with 46mm Frames

Neo Solar Power: D6M_E4A Silver with 35mm Frames

Panasonic: VBHNxxx(KA01, SA16) with 35mm Frames

Panasonic Evervolt: EVPVxxx(Blank, K) with 30mm Frames

Peimar: (OS, SG)xxx(P, M)(Blank, FB) with 40mm Frames

Phono Solar: PSxxxM(1, 4, 6, blank)-(20/U, 20/UH 24/TH) with 35mm, 40mm Frames

REC Solar: RECxxx(PE, PE2SM, PE72, TP, TP2, TP72, TP2S72) (Blank, 50) (Blank, BLK, BLK2) with 30mm, 38mm, 45 mm Frames

RECOM: RCM-xxx-(6MA, 6MB, 6PA, 6PB) with 35mm, 40mm Frames

ReneSola: JCxxxM-24/(Abs, Abw, Bbs, Bbw) with 40mm Frames

Risen: RSM72-6-xxxM with 40mm Frame

S-Energy: SNxxx(P, M)-10 with 40mm Frames

Seraphim Energy Group: SEG-(Blank, 6, B)(Blank, MA, MB, PA, PB)-xxx(BB, BG, HV, WB, WW, BMA-HV, BMA-BG, BMB-HV) with 30mm, 35mm, and 40mm Frames

Seraphim USA: SRP-xxx6(MA, MB, PA, PB)(-)(Blank, BG, HV, DG) with 30mm, 35mm, and 40mm Frames

Sharp Solar: (NT, ND, NE)-(Blank, Q)xxx(UC1, QCJ, QCS, F4, U1, L3EJE, 80EJE) with 46mm Frames

Silfab Solar: S(LA, LG)-(M, X)-xxx with 38mm Frames

Solaria: PowerXT-(xxxR, xxxC)-(AC, BD, PD, PM) with 40mm Frames

Solartech: STU-xxx(PERC, HJT) with 42 mm Frames

SolarWorld: Sunmodule (Plus, BiSun) SWA (Blank, Protect) xxx (MONO, XL, XL MONO, DUO, XL DUO, DUO CLEAR) (Blank) with 33mm Frames

Suniva: (OPT, MVX, ART)xxx-(60, 72)-(4, 5)-(100, 1B0, 800, 8B0) with 35mm, 38mm, 40mm Frames

SunPower: SPR-(E20, E19, P17, X20, X21, X22)-xxx-(Blank, COM, BLK, WHT, C)-(Blank, B, C, D)-(Blank, AC) with 46mm Frames

Talesun Solar: (Blank, HIPRO) TP(660, 672)(M, P, P(H)) xxx with 35mm, 40mm Frames

Tesla: (SC, SC B, SC b1, SCB2)xxx with 40mm Frames

Trina Solar: TSM-xxx-(DD05A, DD14A, PA05, PA14, PC05, PD05, PD14, PE14, DD14A(II), DE14A(II))(Blank, .08(II), .05(II), .08, .05, .10, .18, STD MONO, PERC MONO) with 35mm, 40mm Frames

Upsolar: UP-Mxxx(M, P)(-B) with 35mm, 40mm Frames

URE: (D2L, D6L, D1K, D2K, D6M, D7M, D7P, F2K, F7K, FAK, F7E, F2M, F6M, F7M, F6P)_(C8G, O3A, O4A, O8A, H3A, H4A, H7A, H8A, H9A, HBA, P8A)(-BS, -BB, Blank) with 35mm, 40mm Frames

Vikram Solar: (SOMERA, ELDORA) VSM72.AAA(.03, .05).04 with 35mm, 40mm Frames

VSUN Solar: VSUNxxx-(60M, 60M-BB, 120M, 60P, 60PH) with 35mm Frames

Winaico: (WSP, WST)-xxx(M6, P6) with 35mm, 40mm Frames

Yingli Solar: YLxxx(P, D)-(29b, 35b, 36b) with 35mm, 40mm Frames

Solar Foundations USA[®] – Limited Product Warranty

1. Limited Product Warranty

Solar Foundations USA[®], Inc. (“Solar Foundations”) warrants to the original purchaser of its structural mounting products (“Products”), and any subsequent owner of the original installation site (“Purchaser”), that the Products shall be free from defects in materials and workmanship that materially impair their structural performance under normal use and service conditions, for a period of twenty-five (25) years from the date of shipment by Solar Foundations USA[®]. The warranty version and installation manual version applicable to a Product are the versions in effect on the date of shipment.

2. Finish Warranty

Solar Foundations warrants that all Products with finishes will be free of visible defects, peeling, and cracking for a period of five (5) years from the date of shipment. This Finish Warranty does not apply to mill finish products, pre-plated steel, or polymeric components. It shall be void if the Product is installed in corrosive environments or if proper surface maintenance is not performed in accordance with ASTM A780 or other applicable industry standards. This Finish Warranty does not cover damage resulting from improper outdoor storage prior to installation, including exposure to rain, humidity, or accumulated moisture while the Product is bundled.

3. Transferability

This Limited Warranty is transferable to subsequent owners of the original installation site, provided the Product remains installed at its original location and the new owner submits written notice of the ownership transfer, along with proof of original purchase. The Warranty Period shall not be extended or reset upon transfer.

4. Maintenance and Inspection

Purchaser is responsible for periodic visual inspection of the Product and for performing protective maintenance as needed based on observed conditions and site environment. Particular attention should be given to ground screw at-grade transitions, weld points, cut ends, drilled or modified surfaces, and bolted connections. Maintenance includes application of cold galvanizing compound or equivalent corrosion protection to exposed or damaged steel surfaces. For installations in marine, coastal, or other elevated-corrosion environments, more frequent inspection and protective maintenance may be required based on site conditions.

5. Warranty Exclusions

This Limited Warranty does not cover:

- a. Damage or failure due to shipping, mishandling, storage, improper installation, or improper use;
- b. Damage caused by force majeure events, including but not limited to fire, flood, earthquake, storm, hurricane, or other natural disasters, war, terrorism, acts of foreign enemies, or criminal acts;
- c. Environmental exposure beyond design parameters, including corrosive atmospheres or corrosive soil conditions;
- d. Normal wear and tear, cosmetic changes, or minor surface oxidation. Surface oxidation of mill finish aluminum is normal and is not a defect;
- e. Use in combination with or damage caused by connection to third-party products or alternative materials not provided or approved in writing by Solar Foundations;
- f. Improper use, abuse, alteration, or unauthorized repair of the Product;
- g. Failure to perform inspection and maintenance per Section 4;
- h. External physical forces or events not attributable to a defect in the Product, including but not limited to acts, impacts, or interactions involving natural elements, animals, equipment, or other objects;
- i. Any corrosion or finish degradation resulting from improper outdoor storage, including exposure to moisture while the Product is bundled or left uncovered prior to installation.

6. Remedies and Limitations

If a Product is proven, to Solar Foundations' satisfaction, to be materially defective during the Warranty Period, Solar Foundations will, at its sole discretion, repair the defective Product, replace the defective Product (or part thereof), or refund the original purchase price of the defective Product. Such remedy shall constitute the sole and exclusive remedy available to the Purchaser or transferee. This warranty does not cover costs of shipment, labor, equipment rental, or installation, nor does it cover consequential, indirect, incidental, or special damages, loss of use, revenue, or profit, or claims by third parties, or damages to persons or other property.

7. Warranty Claim Process

To obtain warranty service, the Purchaser (or transferee) must notify Solar Foundations in writing within ten (10) business days after discovering a potential defect, and within the applicable warranty period. Claims must include proof of purchase, site location and installation details, and a description of the defect with supporting photographic documentation. Solar Foundations may require inspection of the Product and documentation before issuing any remedy. All notifications required under this Limited Warranty, including transfer notices and warranty claims, must be submitted in writing to Solar Foundations USA[®] using the contact information published at the time of notice on the company's official website (www.sfusa.com/contact). Notifications may also be sent by mail to Solar Foundations USA, Inc., 1142 River Road, New Castle, DE 19720.

8. Limitation of Implied Warranties

All implied warranties, including but not limited to merchantability and fitness for a particular purpose, are limited in duration to the Warranty Period. No agent, employee, or representative of Solar Foundations is authorized to modify this Limited Warranty. This Limited Warranty shall be governed by and construed in accordance with the laws of the State of Delaware, without regard to its conflict of law principles. Substitutions or modifications approved in writing by Solar Foundations USA do not void this warranty.

9. Severability

If any provision of this Limited Warranty is held invalid or unenforceable, the remaining provisions remain in effect.